

CNC SWISS TYPE AUTOMATIC LATHE

SB-16R/20R type G

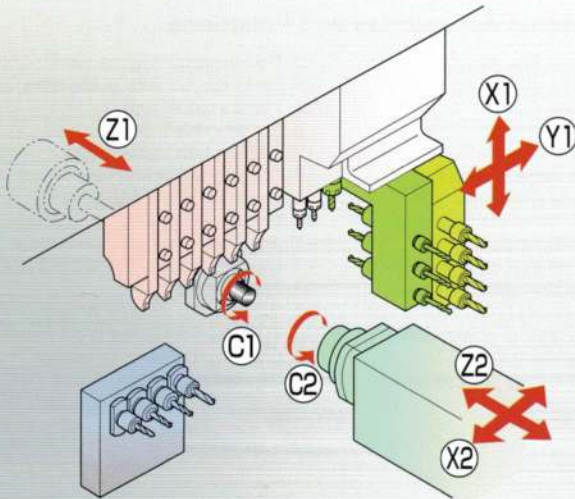

Illustration of tool post:
Cartridge-type 5-spindle cross drilling unit (with Guide Bush)

The Latest Model Joining the SB-R Series with Guide Bush/Non-Guide Bush Switching Function

By selecting a G.B. type, tool post and tool unit and arranging them according to the machining process it enables many different kind of machining option



- For long parts, the G.B. type can be used to regulate material deflection and achieve accurate machining. For short parts, the N.G.B. type can be used to minimize the residual material length and reduce the material cost.
- A movable control panel can be introduced for operation at an optimum position.
- A tool post best suited for the desired machining purpose can be selected from four types.
- The 4-spindle-type unit for back working can readily accommodate rotating tool drive options.
- Both the main spindle and sub spindle are equipped with a C-axis control function as standard equipment.
- The main spindle incorporates a built-in motor to achieve improved indexing accuracy.



The photo shows a non-guide bush type.

G.B.: Guide bush / N.G.B.: Non-guide bush

Four types of tool posts are available to allow for a tooling layout most suited to the required machining applications.

● 4-spindle cross drilling unit	● 5-spindle cross drilling unit	Cartridge-type cross drilling unit ● 5-spindle type ● 5-spindle high-speed type
Tool holder 6 pcs. / 7 pcs.	Tool holder 6 pcs. / 7 pcs.	Tool holder 6 pcs. / 7 pcs.
Cross drill unit 4 spindles(ER16)	Cross drill unit 5 spindles(ER11)	Cross drill unit 2 spindles(ER11)
Sleeve holder 4 pcs.	Sleeve holder 4 pcs.	Cartridge type 3 pos.

Standard Machine Specifications

Item	4-spindle cross drilling unit		5-spindle cross drilling unit		Cartridge-type cross drilling unit				
	16R	20R	16R	20R	5-spindle		5-spindle high-speed		
	16R	20R	16R	20R	16R	20R	16R	20R	
Max. machining diameter	φ16mm (5/8in)	φ20mm (25/32in)	φ16mm (5/8in)	φ20mm (25/32in)	φ16mm (5/8in)	φ20mm (25/32in)	φ16mm (5/8in)	φ20mm (25/32in)	
Max. headstock stroke	G.B. type N.G.B. type		205mm(8in)						
Tool	Bar diameter×2.5(Max.50mm) (Max.1.31/32in)								
4-Spindle sleeve holder	Number of tools		Front 4 tools						
			Rear 4 tools						
	Max. drilling capability		φ12mm(1/2in)						
		Max. tapping capability						M10×P1.5	
Power driven att.	Number of tools		Cross power driven att. 4 tools(ER16)	Cross power driven att. 5 tools(ER11)	Cross power driven att. 2 tools(ER11)				
			Cartridge type: 3Pos						
	Max. drilling capability		ER16 φ7mm(9/32in)	—	φ7mm(9/32in)				
			ER11 —	φ5mm(3/16in)	φ6mm(15/64in) φ5mm(3/16in)				
	Max. tapping capability		ER16 M6×P1.0	—	M6×P1.0				
			ER11 —	M5×P0.8					
Spindle speed		ER16 Max.6,000min ⁻¹	—	Max.6,000min ⁻¹					
		ER11 —	Max.10,000min ⁻¹	Max.8,000min ⁻¹	Max.10,000min ⁻¹				
Drive motor		1.0kw(continuous) / 1.2kw(5min. / 30%ED)							
Rapid feed rate	35m/min(X1,Y1,Z1,X2,Z2)								
Main spindle indexing angle	C-axis control								
Main spindle speed	Max.10,000min ⁻¹								
Main spindle motor	2.2kw(continuous) / 3.7kw(10min. / 25%ED)								
Coolant tank capability	180ℓ								
Dimensions (W×D×H)	2,070×1,177×1,760mm								
Center height	1,060mm								
Weight	1,700kg								
Power consumption	3.7KVA								
A-weighted sound pressure	74dB								

Backworking Attachment Specifications

OP : Option

Item	Specifications	
	16R	20R
Max. chucking diameter	φ16mm(5/8in)	φ20mm(25/32in)
Max. length for front ejection	80mm (3-5/32in)	
Max. parts projection length	30mm (1-11/64in)	
	Number of tools	
	4 tools	
Back 4-Spindle unit	Max. drilling capability	Stationary tool φ8mm(5/16in)
		Power driven tool φ6mm(15/64in)
	Max. tapping capability	Stationary tool M6×P1.0
		Power driven tool M5×P0.8
Power-driven att. spindle speed	Max.8,000min ⁻¹ : OP	
Power-driven att. drive motor	0.75kw : OP	
Sub spindle indexing angle	C-axis control	
Sub spindle speed	Max.9,000min ⁻¹	
Sub spindle motor	0.55kw(continuous) / 1.1kw(15min. / 40%ED)	

Note)
The machining capacities apply to SUS303 material. The machining capacities may differ from listed values depending on the machining conditions, such as the material to be machined or the tools to be used.

- note-1 : ● Measures conforming to ISO standard.
● A-weighted sound pressure is a general assessment standard characteristic that corrected the sound level to human acoustic sense.

*Design features, specifications and technical execution are subject to change without prior notice.

*This product is an export control item subject to the foreign exchange and foreign trade laws. Thus, before exporting this product, or taking it overseas, contact your STAR MICRONICS dealer.

Standard Accessories and Functions

- CNC unit FANUC Oi-TD
- Operation panel 8.4-inch color LCD display
- Pneumatic unit
- Automatic centralized lubrication unit
- Coolant level detector
- Door interlock system
- Broken cutoff tool detector
- Parts ejection detector
- Drive unit for revolving guide bush
- Revolving guide bush unit
- Main/Sub collet
- C-axis control (Main/Sub)
- Spindle clamp unit (Main/Sub)
- Tool holder
- 4-spindle cross drilling unit
- 4-spindle sleeve holder
- Back 4-Spindle unit
- Air purge for revolving guide bush
- Sub spindle air purge unit
- Sub spindle air blow unit
- Work light
- Leakage breaker

Optional Accessories and Functions

- Coolant flow detector
- Water removal unit
- Beacon
- Parts conveyor
- Parts receptacle in the machine
- Parts separator unit A
- Main spindle inner tube
- 5-spindle cross drilling unit
- Cartridge-type 5-spindle cross drilling unit
- Cartridge-type 5-spindle high-speed cross drilling unit
- Drive unit for power-driven attachment B
- Parts ejector (Air cylinder type)
- Parts ejector (Spring type)
- Parts ejector with guide tube
- Parts stopper unit
- Coolant unit 2.5MPa
- Coolant unit signal cable
- Coolant unit power cable
- Coolant valve 2.5MPa
- Coolant pipings
- Automatic bar feeder interface
- Compliant with the RS-232C interface
- Transformer
- Safety relay module version
- Transformer CE marking version
- Cable for CE marking version
- CE marking version

External Dimensions and Floor Space

unit : mm(ft)

Barfeeder

Type	Length	A (mm)		
		2.5M	3.0M	4.0M
Z-16		3,386(11.11)	3,886(12.75)	4,886(16.02)
ASRX-20AS		3,386(11.11)	3,886(12.75)	4,886(16.02)
OS20S		3,560(11.68)	4,060(13.32)	—
OS203E		3,644(11.95)	4,094(13.43)	4,949(16.23)

Overall height : 1,760mm(5.77)

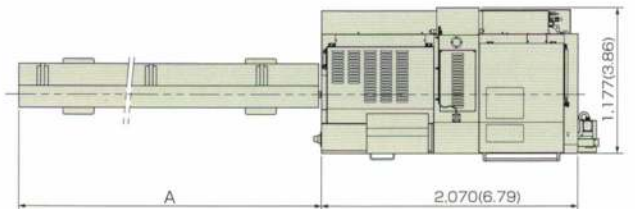

STAR MICRONICS CO., LTD.

Machine Tools Division

1500-34 Kitanoya, Misawa, Kikugawa, Shizuoka, 439-0023 Japan

America, Europe Sales TEL.+81-537-36-5594 FAX.+81-537-36-5607

Asia Sales TEL.+81-537-36-5574 FAX.+81-537-36-5607

Star CNC Machine Tool Corporation

123 Powerhouse Road, Roslyn Heights, NY 11577, U.S.A.
TEL.+1-516-484-0500 FAX.+1-516-484-5820

Star Micronics GB Limited

Chapel Street, Melbourne, Derbyshire DE73 8JF, U.K.
TEL.+44-1332-86-44-55 FAX.+44-1332-86-40-05

Star Micronics GmbH

Robert-Grob-Str. 1, D-75305 Neuenbürg, Germany

Star Micronics AG

Lauetstrasse 3, CH-81 12 Otelfingen, Switzerland
TEL.+41-43-411-60-60 FAX.+41-43-411-60-66

Star Machine Tool France

90 Allée de Glaisy, Z 1, 74300 Thyez Haute Savoie, France
TEL.+33-450-96-05-97 FAX.+33-450-96-91-54

Shanghai Xingang Machinery Co., Ltd.

229 Fute Road(N) Waigaoqiao F. T. Z. Shanghai 200131, P.R.China
TEL.+86-21-5868-2100 FAX.+86-21-5868-2101

Star Micronics (Thailand) Co., Ltd.

26/59 1st/3rd Floor, M7 Sol Kingkaew 62/2 Kingkaew Road, T.Rachathewa A.Bangplee Samutprakom 10540
TEL.+66-(0)2-175-1923-25 FAX.+66-(0)2-175-1926

9001 ISO 14001
CERTIFIED

<http://www.star-m.jp/eng/>