



# EUROTECH

# TC800

Precise Universal Lathe



Mechanical Engineering  
**Made in Europe**

[www.eurotechelite.com](http://www.eurotechelite.com)  
[sales@eurotechelite.com](mailto:sales@eurotechelite.com)

# Machine Highlights

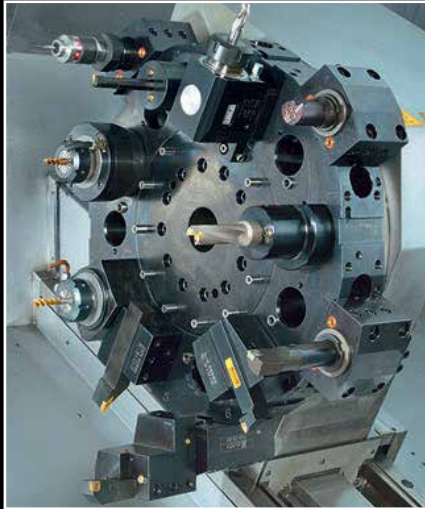

Turret VDI50 of TC800-MC

Available with or without driven tools and Y axis

Ideal for Hard Turning and Heavy-Duty Cutting

2 large panoramic windows to the working area \*

Chip conveyor as standard

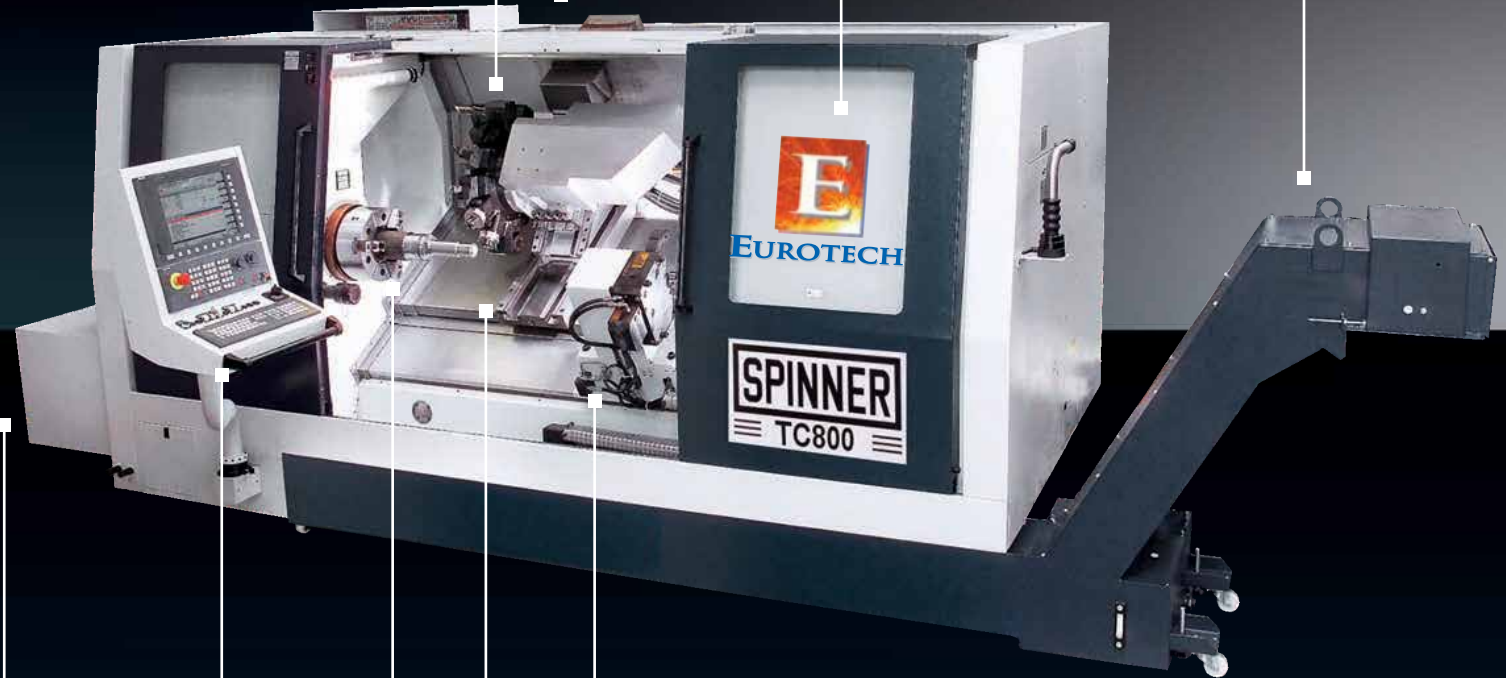

Real slant bed design for optimised chip fall

Toolsetter and tailstock as standard

Small distance between operator and chuck

Latest control system:  
Siemens 840D-SL, Fanuc 32iT

Machining of bars

Rigid  
Stiff  
Durable  
Precise  
Universal

Servo turret with  
toolholder  
VDI50/VDI40/BMT65

Up to 16 driven tools

Real Y axis

Picture shows machine  
TC800-110L-MCY with  
beltspindle

Rigid machine  
base as a one-  
piece casting

Dynamic motorspindle  
with 85 mm bore or  
powerful beltspindle with  
gear and 110 mm  
bore for high torque

Hardened and ground sliding  
guideways for best vibration  
damping

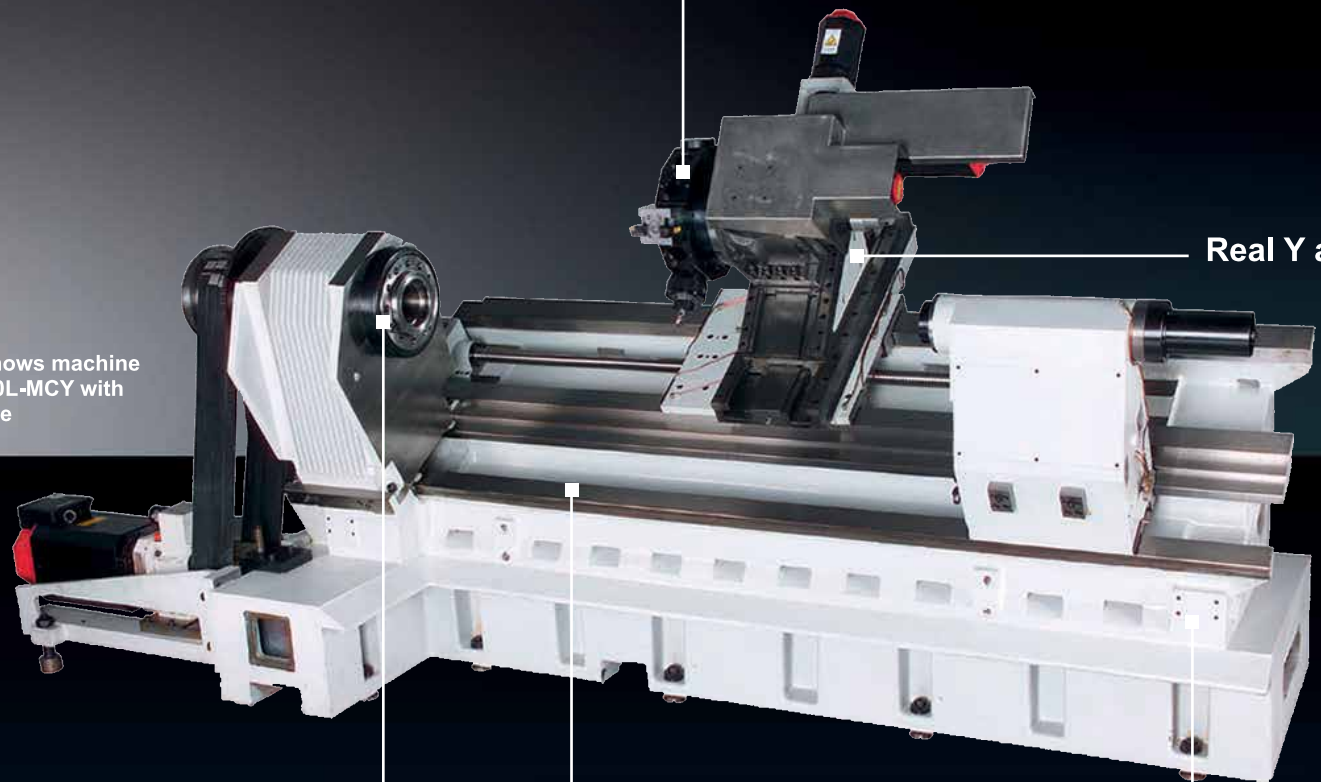

Working area	TC800-85	TC800-110 / TC800-110L
Swing diameter	~800 mm	
Max. turning diameter	~500 mm	
Max. turning length	900 mm	900 mm / 1580 mm (L)
X-axis	~360 mm	
Y-axis (option)	+65 / -55 mm	
Z-axis	900 mm	900 mm / 1580 mm (L)
<b>Axes</b>		
Rapide traverse X / Z	15 / 24 m/min	
<b>Spindle 1</b>		
Max. spindle speed	3.400 rpm	2.600 rpm
Spindle nose	A8/DIN	A11/DIN
Chuck diameter	250 mm (optional 315 mm)	315 mm (optional 400/500 mm)
Spindle bore	85 mm	110 mm
Performance $P_{max}$	95 kW	63 kW
Torque $M_{max}$	930 Nm	Gear range 1: 2250 Nm Gear range 2: 562 Nm
<b>Spindle 2</b>		
Max. spindle speed	5.000 rpm	
Spindle nose	A6/DIN	
Chuck diameter	210 mm	
Performance $P_{max}$	23,5 kW	
Torque $M_{max}$	150 Nm	
<b>Turret</b>		
Number of tool stations	12xVDI50 / (optional 16xVDI40/12xBMT65)	
Number of driven tools (option)	12 (8/12)	
Toolholder	VDI50 (optional VDI40 / BMT65)	
Max. speed of driven tools	4.000 rpm	
Performance $P_{max}$	37 kW	
Torque $M_{max}$	80 Nm	
<b>General indications</b>		
Dimensions (L x W x H) <sup>1)</sup>	4700 x 1980 x 2115 mm	4950/5750 x 1980 x 2090 mm
Weight <sup>2)</sup>	~7.000-7.500 kg <sup>3)</sup>	~7.000-7.500 kg / ~8.000-8.500 kg <sup>3)</sup>

1) See floorplan

2) Machine net weight SMCY

3) According to the equipment

Main spindle TC800-110 2.600 rpm; gear range 1 and 2

Gear range 1

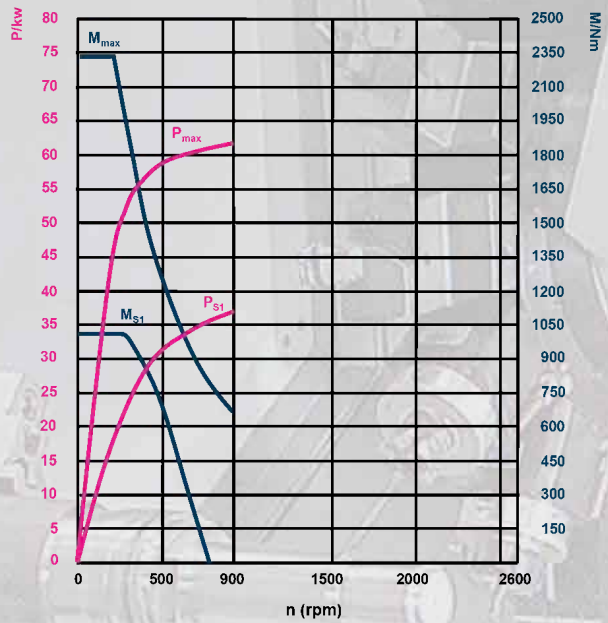

Gear range 2

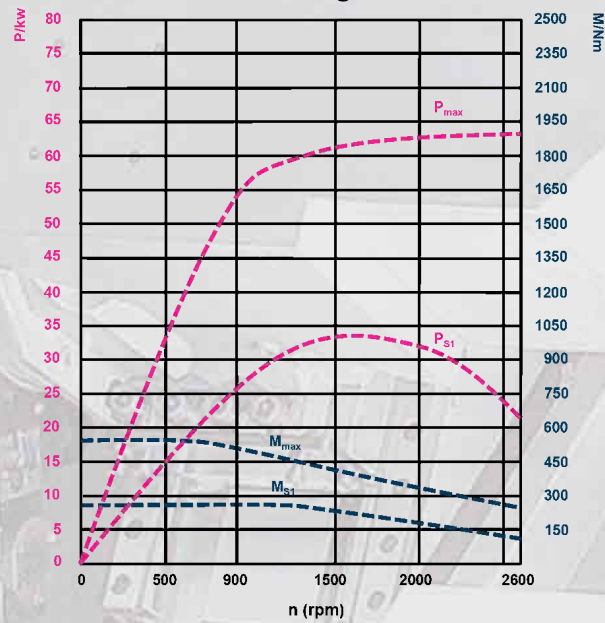

Main spindle TC800-85 3.400 rpm

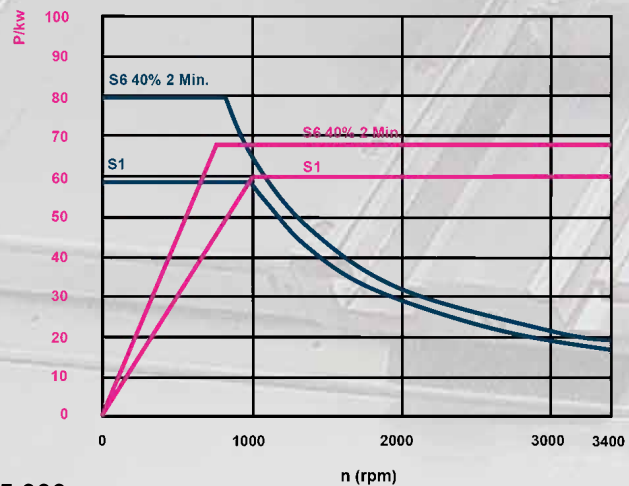

Sub spindle 5.000 rpm

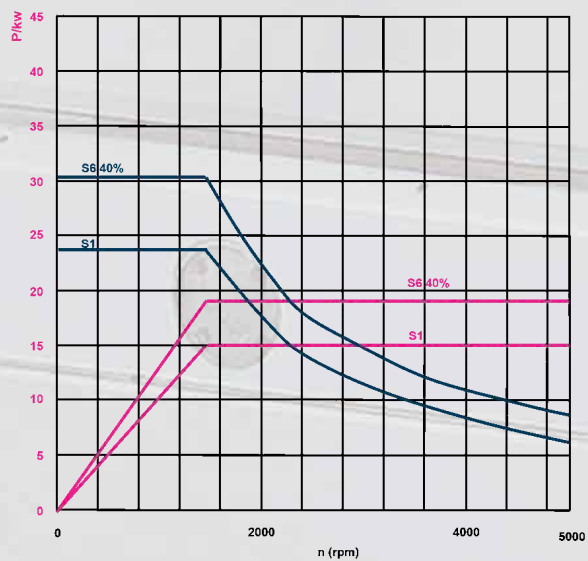

Driven tool

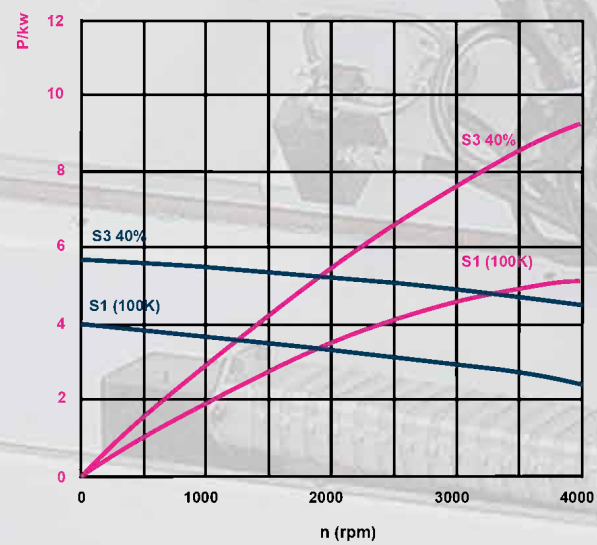

Clamping force control by differential pressure for main spindle and/or sub spindle

Siemens 840D-SL Fanuc 32iT

- Turret disc VDI40 16-position (VDI50 as standard)
- Turret disc BMT65 12-position
- Toolholder package VDI50
- Component measurement by touch probe in turret

Steady rest

Suction unit for coolant mist  
Fire extinguishing system

External tool measurement



Clamping system for the workpiece

Bar feeder

Part catcher \*

High pressure coolant pump  
15/50 bar for tools with internal coolant supply

Automatic door

Glass scale  
X-axis / Z-axis

Coolant pistol in the working area



\* Part catcher can not be combined with panoramic window

Other options on demand

**TC800-85**

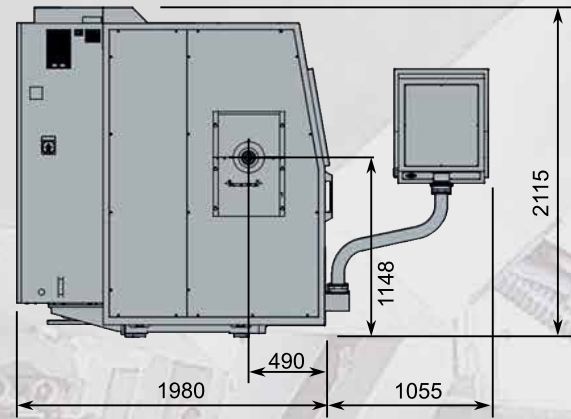
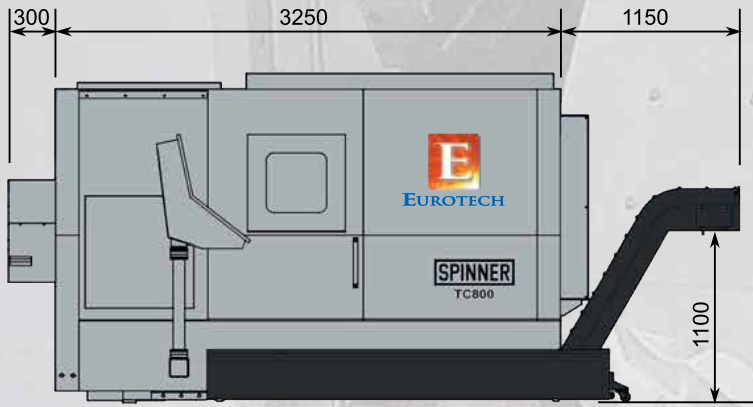

**TC800-110**

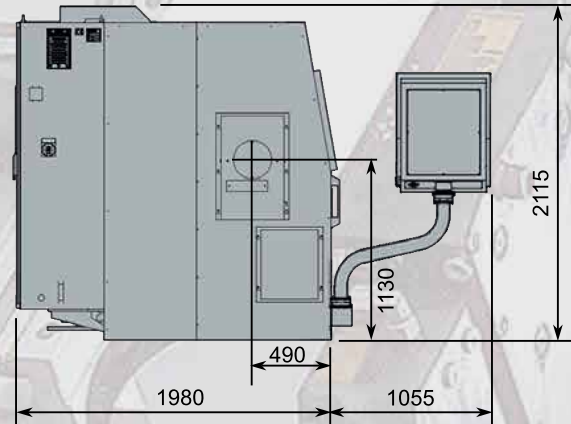
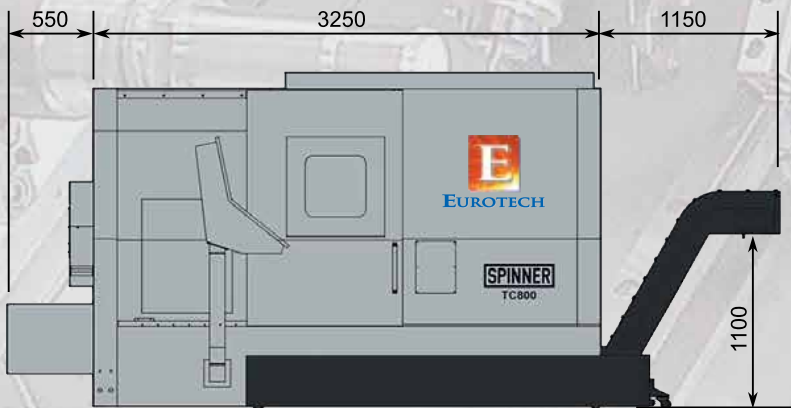

**TC800-110L**

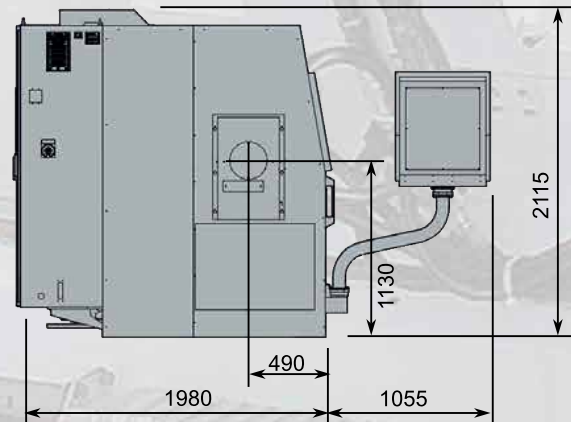
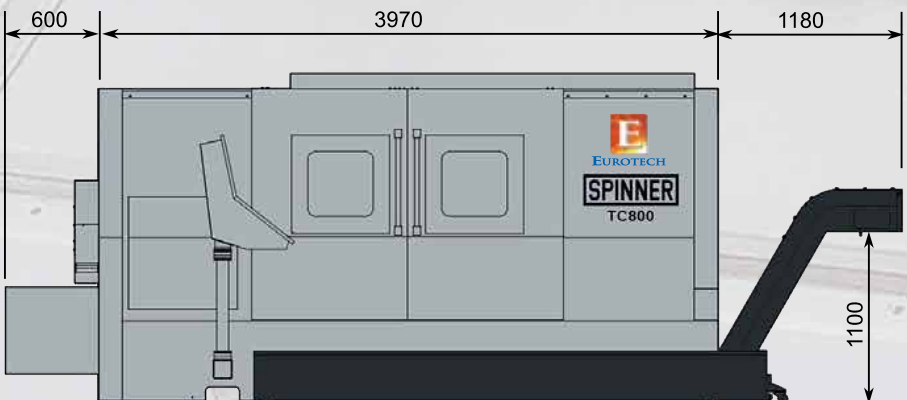

■ Version with standard chip conveyor



# EUROTECH

# SPINNER



Spinner has designed and produced the most modern machine-tools since 1950. More than 20.000 delivered machines demonstrate their high efficiency, precision and reliability, everyday.

Spinner produces and sells more than 1,000 CNC machines a year; and the number increases every year, combining the know-how of a global player with the flexibility and cost-effectiveness structures of a family owned business.

EUROTECH

tele: 352-799-5223 | email: [sales@eurotechelite.com](mailto:sales@eurotechelite.com)

fax: 352-799-4662 | web: <http://eurotechelite.com>

Version 3.6.2015

Technical changes of specifications and pictures are subject to change without notice - Pictures can include options, accessories